

BJ130-A

成套钩形夹具



M8型



M12型

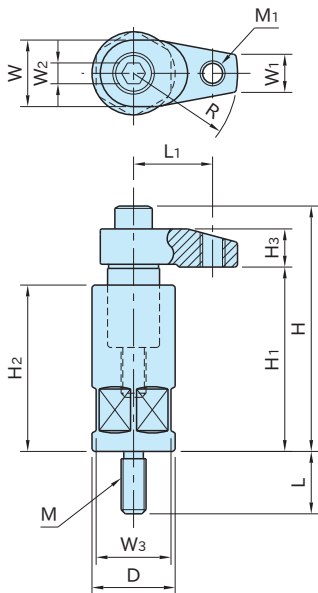

钩子	钩柄
SCM435 淬火回火 四氧化三铁膜 精密研磨	S45C 四氧化三铁膜

★One Point
省空间型夹具

型 号	H ₁	M ₁	L ₁	R	D	H ₂	M	L	H
BJ130-08020A1	55~65	-	-	20	24	55	M 8×1.25	19	69~ 79
BJ130-08025A1				25					
BJ130-08030A1				30					
BJ130-10030A1	63~75	-	-	30	32	63	M12×1.75	30	87~ 99
BJ130-10030A2	80~92								104~116
BJ130-10040A1	63~75			63					87~ 99
BJ130-10040A2	80~92			80					104~116

型 号	W	W ₁	H ₃	W ₂	W ₃	夹紧力 (kN)	容许紧固扭矩 (N·m)	质量 (kg)
BJ130-08020A1	22	10	12	6	22	12	30	0.23
BJ130-08025A1						11		0.24
BJ130-08030A1						10		0.25
BJ130-10030A1	25	12	15	8	30	13	38	0.60
BJ130-10030A2						0.70		
BJ130-10040A1						10	32	0.61
BJ130-10040A2						0.71		

相关产品页

备有调节高度用 [BJ600](#) 联结杆。(参照P.492)

注意事项

不使用切削液加工时，为了防止夹紧松开时的卡死，请在产品滑动面涂抹润滑油。

使用示例及使用方法

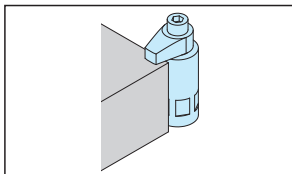

型 号	H ₁	M ₁	L ₁	R	D	H ₂	M	L	H				
BJ130-12040A1	80~95	-	-	40	40	80	M12×1.75	30	107~122				
BJ130-12040A2	100~115					100			127~142				
BJ130-12050A1	80~95					80			109~124				
BJ130-12050A2	100~115					100			129~144				
BJ130-12060A1	80~95					80			109~124				
BJ130-12060A2	100~115					100			129~144				
BJ130-12140A1	80~95			M12×1.75		31			40	80	107~122		
BJ130-12140A2	100~115									100	127~142		
BJ130-12150A1	80~95									80	109~124		
BJ130-12150A2	100~115									100	129~144		
BJ130-12160A1	80~95									80	109~124		
BJ130-12160A2	100~115									100	129~144		
BJ130-16040A1	80~95	-	-	40	50	80	M16×2	30	116~131				
BJ130-16040A2	100~115					100			136~151				
BJ130-16050A1	80~95					80			116~131				
BJ130-16050A2	100~115					100			136~151				
BJ130-16060A1	80~95					80			116~131				
BJ130-16060A2	100~115					100			136~151				
BJ130-16150A1	80~95			M12×1.75		38			50	80	116~131		
BJ130-16150A2	100~115									100	136~151		
BJ130-16160A1	80~95									80	116~131		
BJ130-16160A2	100~115									100	136~151		
BJ130-16160A1	80~95									46	60	80	116~131
BJ130-16160A2	100~115											100	136~151

型 号	W	W ₁	H ₃	W ₂	W ₃	夹紧力 (kN)	容许紧固扭矩 (N·m)	质量 (kg)			
BJ130-12040A1	32	18	16	10	36	15	50	1.36			
BJ130-12040A2								1.56			
BJ130-12050A1								18	14	1.39	
BJ130-12050A2										1.59	
BJ130-12060A1								18	12	46	1.43
BJ130-12060A2											1.63
BJ130-12140A1			16			15	50				1.36
BJ130-12140A2											1.56
BJ130-12150A1			18			14	80				1.39
BJ130-12150A2											1.59
BJ130-12160A1								12	46	1.43	
BJ130-12160A2										1.63	
BJ130-16040A1	36	22	21	14	46	18	80	2.11			
BJ130-16040A2								2.42			
BJ130-16050A1								16.5	2.16		
BJ130-16050A2										2.47	
BJ130-16060A1								16	2.22		
BJ130-16060A2										2.53	
BJ130-16150A1										16.5	2.16
BJ130-16150A2											
BJ130-16160A1										16	2.22
BJ130-16160A2											